

SMART Board® GX (V3) series



Display	
Screen sizes (diagonal)	65" 75" 86"
Backlight	LED
Aspect ratio	16:9
Maximum display resolution	4K UHD (3840 × 2160)
Refresh rate	60 Hz
Lifespan	≥ 50,000 hours
Brightness¹	400 cd/m ²
Display response time	≤ 8 ms
Viewing angle	178°
Glass	Full heat-tempered Anti-glare Bonded
Frame color	Black
Convenience buttons	Power Home Volume Freeze frame
Sensors	Ambient light Infrared
Audio	2 integrated 20W speakers with high fidelity audio

Interactive experience	
Touch technology	Advanced infrared
Touch features	Simultaneous tool differentiation ² Object Awareness™ ³ Silktouch™
Typical touch response time	≤ 8 ms
Frame rate	≥ 125 Hz
Accuracy	1 mm
Minimum object size	2 mm
Multitouch capabilities	40 – Windows® 32 – Android™ 20 – Mac 10 – Chrome OS™
Tools included	Pens (x2)
Tool holders	Magnetic Frame-mounted
Software	
Included	Embedded Android OS SMART Notebook® SMART Product Drivers and SMART Ink®
Optional	SMART Notebook Plus Lumio™ by SMART SMART Meeting Pro® SMART TeamWorks™ SMART Remote Management

¹Brightness of individual displays can vary.

²A connected computer with SMART Product Drivers is required.

Only supported in SMART Notebook and SMART Ink.

³When connected to a computer with SMART Product Drivers

Embedded Android OS

Operating system	Android version 11.0 (upgradable to Android 13.0) ⁴
CPU	Quad-core
Memory	8 GB DDR4
Storage	64 GB
Digital whiteboard	✓
Web browser	✓
Screen sharing	✓
Other features	Input select File manager Overlay Split screen Picture-in-picture (PIP) with touch pass-through Interactive widgets App library
WPS Office	✓
Ability to run third-party applications	✓
Cloud storage access	✓
Languages supported	Arabic Bulgarian Chinese (simplified) Chinese (traditional) Croatian Czech Danish Dutch English Estonian Finnish French German Greek Hungarian Indonesian Italian Japanese Korean Latvian Lithuanian Norwegian Polish Portuguese Romanian Russian Serbian Spanish Swedish Thai Turkish Ukrainian Vietnamese
Updates	Over-the-air (OTA)

PC computing

OPS support⁵	SMART PCM modules
PC module power supported OPS	90 W
Optional computing module	See > smarttech.com/accessories

Inputs	Front	Back
OPS PC accessory slot	–	1
HDMI® 2.0 with HDCP 1.4 and HDCP 2.2 support	1	2
Display Port 1.2	–	1
VGA video	–	1
Stereo 3.5 mm (variable)	–	1
RS-232 (DB-9 connector)	–	1
RJ45 (LAN IN)	–	1
USB Type-C 4K @ 60Hz Display Port alternate mode, touch, digital audio, USB 3.2 Gen 1 (DFP) for peripherals; 15 W power delivery	1	–
USB Type-C 4K @ 60Hz Display Port alternate mode, touch, digital audio, USB 2.0 Hi-Speed USB	–	1
USB 2.0 Type-A	–	1
USB 3.2 Gen 1 Type-A	2	2
USB 2.0 Type-B	1	1

Outputs	Front	Back
HDMI 2.0 with HDCP 1.4 and 2.2 support	–	1
Stereo 3.5 mm (variable)	–	1
S/PDIF optical (fixed)	–	1
RJ45 (LAN OUT)	–	1

Included cables and accessories	Qty
Country-specific power cable	1
16' 5" (5 m) USB 2.0 A to B cable	1
Pens	2
External dual-band Wi-Fi (2.4 and 5 GHz) and Bluetooth® (2.4 GHz) antennas	2
Remote control	1
AAA batteries	2
Illustrated installation instructions	1
Important information document	1

⁴Update available in 2024 using a USB drive (not available OTA).

⁵The support and performance of third-party OPS (Open Pluggable Specification) and OPS-C modules may vary. Conduct proper compatibility testing to avoid potential issues.

Connectivity

Wired	RJ45 (x2) 1000baseT
Wi-Fi	IEEE 802.11ax (Wi-Fi 6) supporting WEP, WPA, WPA2, WPA3 PSK, and 802.1X EAP authentication protocols Wi-Fi access point
Bluetooth	5.0 dual mode

Storage and operating requirements

Power requirements	100V to 240V AC, 50 Hz to 60 Hz
Operating temperature	32–104°F (0–40°C)
Storage temperature	14–140°F (-10–60°C)
Humidity	20–80% relative humidity, non-condensing

Power consumption

Typical	65": 79 W 75": 88 W 86": 119 W
Standby	<0.5 W

Certification and compliance⁶

Regulatory models	IDGX65-2 IDGX75-2 IDGX86-2
US / Canada	cULus FCC ISED TSCA CONEG Packaging Proposition 65
EU / EEA / EFTA / UK	CE UKCA LVD CB EMCD RED REACH RoHS Battery WEEE Packaging POP Ecodesign
Australia / New Zealand	RCM
Performance standards	ENERGY STAR® HDMI HDCP

Purchasing information⁷

Order numbers

GX165-V3	SMART Board® GX065-V3 interactive display with embedded OS
GX175-V3	SMART Board GX075-V3 interactive display with embedded OS
GX186-V3	SMART Board GX086-V3 interactive display with embedded OS

Optional accessories

See > smarttech.com/accessories

SMART Warranty

Terms and conditions and warranty upgrade options vary by region. Visit smarttech.com/warranty or contact your reseller for information.

Cable requirements

See > [SMART cables and connectors guide \(docs.smarttech.com/kb/171926\)](https://docs.smarttech.com/kb/171926)



⁶Product availability may vary by region.

This product has received additional certifications not listed here.

⁷Order numbers may vary by region.

Installation, dimensions, and weights

Notes

- All dimensions $\pm 1/8"$ (0.3 cm). All weights ± 2 lb. (0.9 kg).
- Product ships upright.

65" models

Dimensions

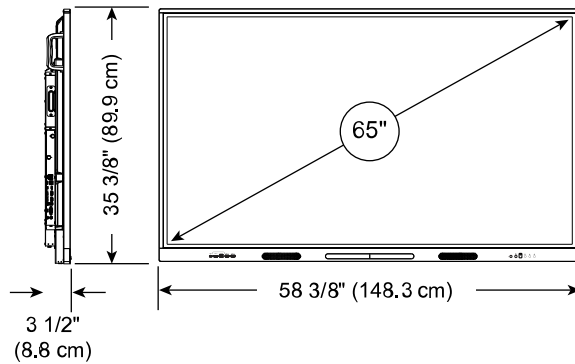

Weight

82 lb. (37 kg)

Shipping dimensions (including pallet)

63 3/4" \times 45 7/8" \times 6 1/4"
(162 cm \times 116.5 cm \times 16 cm)

Shipping weight

118 lb. (54 kg)

VESA mount

M8 | 600 \times 400 mm

Handles

2

75" models

Dimensions

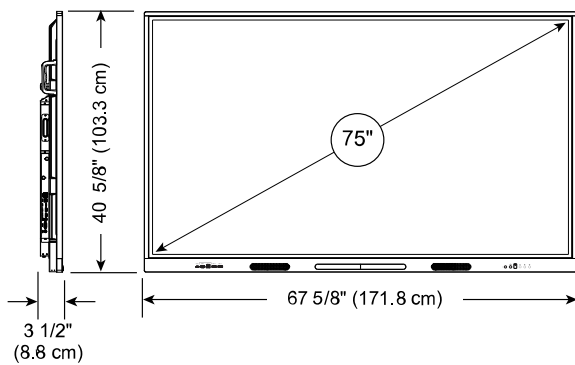

Weight

114 lb. (52 kg)

Shipping dimensions (including pallet)

71 5/8" \times 50 5/8" \times 6 1/4"
(182 cm \times 128.5 cm \times 16 cm)

Shipping weight

158 lb. (71 kg)

VESA mount

M8 | 800 \times 400 mm

Handles

2

Installation, dimensions, and weights (continued)

86" models

Dimensions

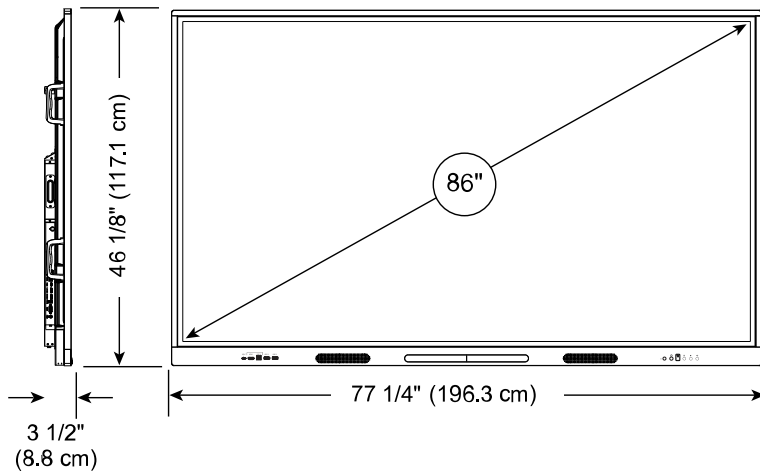

Weight

143 lb. (65 kg)

Shipping dimensions (including pallet)

85 1/4" × 56 7/8" × 6 1/4"
(216.5 cm × 144.5 cm × 16.0 cm)

Shipping weight

198 lb. (90 kg)

VESA mount

M8 | 800 × 600 mm

Handles

4

smarttech.com

© 2024 SMART Technologies ULC. All rights reserved. SMART Board, SMART Notebook, Lumio by SMART, SMART Meeting Pro, SMART TeamWorks, SMART Ink, Simultaneous Tool Differentiation, Object Awareness, Silktouch, smarttech, the SMART logo and all SMART taglines are trademarks or registered trademarks of SMART Technologies ULC in the US and/or other countries. The Adopted Trademarks HDMI, HDMI High-Definition Multimedia Interface, and the HDMI Logo are trademarks or registered trademarks of HDMI Licensing Administrator, Inc. in the United States and other countries. The Bluetooth word mark is owned by the Bluetooth SIG, Inc. and any use of such marks by SMART Technologies ULC is under license. Android and Chrome OS are trademarks of Google Inc. All other third-party product and company names may be trademarks of their respective owners. This product and/or use thereof is covered by one or more of the following US patents: www.smarttech.com/patents. Contents are subject to change without notice. March 20, 2024.

docs.smarttech.com/kb/171902

